

Pro-Target

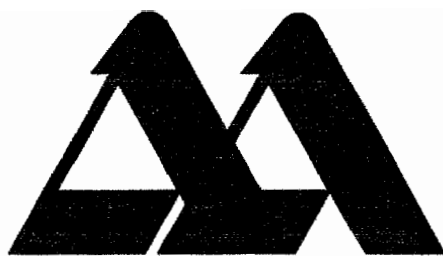

Pro-Target

AIR ARMS
World Class Air Rifles

USERS HANDBOOK

THIS HANDBOOK REFERS TO PRO-TARGET Mk3 MODELS FT & TH

CONGRATULATIONS ---- You are now the owner of a Pro-Target Mk3

Treated with the care that any precision instrument warrants, this rifle will give you good sport and reliable service.

***PLEASE READ THIS HANDBOOK BEFORE USING YOUR RIFLE,
IT CONTAINS IMPORTANT SAFETY & MAINTENANCE INFORMATION***

***ALWAYS BE AWARE THAT YOUR ACTIONS WILL BE UNDER THE SCRUTINY OF
OTHER MEMBERS OF THE PUBLIC WHO MAY NOT SHARE YOUR ENTHUSIASM
FOR AIR WEAPONS. BAD PRACTICES PROMOTE BAD PUBLICITY.***

***** THE SAFETY CODE *****

- 1 TREAT ALL AIR WEAPONS AS IF LOADED.***
- 2 NEVER POINT ANY WEAPON AT ANYONE, EVEN IF IT IS UNLOADED.***
- 3 NEVER LEAVE YOUR RIFLE COCKED OR LOADED.***
- 4 ALWAYS BE SURE OF WHAT LIES BEYOND YOUR TARGET.***
- 5 ALWAYS CONDUCT YOURSELF IN A SPORTSMAN-LIKE MANNER.***

ALWAYS ---- REMEMBER AND APPLY THE SAFETY CODE

THE AIR CYLINDER IS A HIGHLY PRESSURISED UNIT AND MUST NOT BE MODIFIED OR MACHINED IN ANY WAY. DO NOT ATTEMPT TO PRESSURISE IF THERE ARE ANY LARGE SURFACE ABRASIONS OR DENTS. DO NOT STORE THE RIFLE IN PLACES SUBJECT TO HIGH TEMPERATURES .I.E. CLOSE TO FIRES OR BOILERS. DO NOT ATTEMPT TO DISMANTLE WHEN PRESSURISED, SEVERE PERSONAL INJURY MAY RESULT. DO NOT PRESSURISE BEYOND THE STATED MAXIMUM FILLING PRESSURE. ONLY USE CLEAN FILTERED COMPRESSED AIR. NEVER USE ANY OTHER GAS, PARTICULARLY INDUSTRIAL OR WELDING GASES SUCH AS OXYGEN, CARBON DIOXIDE, ACETYLENE, HYDROGEN, NITROGEN, ARGON ETC.

THIS RIFLE HAS BEEN SET UP AND TESTED ON AIR ARMS PELLETS (SEE PAGE 12). IF ANY OTHER MAKE OR TYPE OF PELLET IS USED, THE RIFLE MUST BE RE-TESTED TO ENSURE THE MUZZLE ENERGY IS WITHIN THE LEGAL LIMIT.

WARNING - UNAUTHORISED DISASSEMBLY OF YOUR RIFLE WILL INVALIDATE THE WARRANTY.

CAUTION! : THIS AIR RIFLE IS NOT A TOY AND MAY CAUSE DEATH OR SERIOUS INJURY IF MISUSED OR USED CARELESSLY.

READ ALL INSTRUCTIONS BEFORE USE.

THE PURCHASER AND/OR USER HAS THE RESPONSIBILITY TO CONFORM TO ALL LEGISLATION RELATING TO THE OWNERSHIP AND USE OF AIR WEAPONS WITHIN THE COUNTRY OF USE.

IN THE UNITED KINGDOM, THIS AIR RIFLE REQUIRES ADULT SUPERVISION IF THE USER IS UNDER 14 YEARS OLD. THE SUPERVISOR MUST BE AT LEAST 21 YEARS OLD.

******* WARRANTY *******

THIS PRODUCT HAS A LIMITED 12 MONTH BACK-TO-BASE PARTS & LABOUR WARRANTY COMMENCING FROM THE DATE OF PURCHASE THE. WARRANTY IS LIMITED TO DEFECTS IN MATERIALS AND/OR WORKMANSHIP AND IS TRANSFERABLE WITHIN THE 12 MONTH PERIOD. PROOF OF PURCHASE IS REQUIRED TO RECEIVE WARRANTY REPAIRS. RETAIN YOU RECEIPT AND RETURN THE WARRANTY REGISTRATION CARD STAMPED OR SIGNED BY THE SUPPLIER.

WHAT IS COVERED:

REPLACEMENT PARTS AND LABOUR.

RETURN TRANSPORTATION TO THE CONSUMER (MAINLAND UK ONLY).

WHAT IS NOT COVERED:

TRANSPORTATION FROM THE CONSUMER TO AIR ARMS.

DAMAGE CAUSED BY MISUSE, ABUSE, LACK OF ROUTINE MAINTENANCE OR DIS-ASSEMBLY.

PARTS SUBJECT TO NORMAL WEAR AND TEAR.

ANY OTHER CONSEQUENTIAL COST TO THE CONSUMER.

RETURN TRANSPORTATION TO THE CONSUMER.

***** IMPORTANT INFORMATION *****

Do not store the rifle in a damp place such as a garden shed or garage.

Do not store the rifle in a plastic or pvc type gun bag.

Never leave it in a cocked condition.

Always ensure the breech block is fully closed before firing.

VERY IMPORTANT INFORMATION, PLEASE READ

VELOCITY, MUZZLE ENERGY AND THE LEGAL USE OF AIR RIFLES.

The current laws on the ownership and use of air rifles make it very difficult for manufacturers to meet the needs of both the shooter and legislation when it comes to performance.

New or different pellets, lubricants and after-market services can alter the velocity of an air rifle significantly, long after the rifle has left the factory. Even the running-in process associated with any new product can alter the performance. These variables result in removal of any control by the manufacturer.

Because of this, we have adopted the principle that all of our air rifles will be set up on Air Arms brand of pellet. This choice is made on the basis that these pellets represent the best combination of quality, efficiency, price and availability. Whether the set up is changed or not, it is advisable to check the performance regularly, particularly after the running-in period.

Our rifles can be set up to suit any pellet that is or will come onto the market, however it must be advised that some will result in over power performance. If the owner/user decides to use a different pellet or alter the set up they must realise that the responsibility to check conformity with all relevant legislation rests on their shoulders.

It is a very serious offence to be in possession of an over powered air rifle and, if conviction results, can mean confiscation, a heavy fine, or imprisonment even a combination of all three.

AIR ARMS rifles are currently set up at the factory to produce between 11.3 and 11.5ft/lbs. This is to allow for any slight increase in performance after the running-in period, approximately 2000 shots. Please refer to the pellet table inside the back page for the type of pellet used to test and set up your rifle.

CHECKING PERFORMANCE

- Use a reliable chronograph to check the pellet velocity. To use the formula below the reading must be in feet per second (FPS).
- Use fine measurement scales to check the pellet weight. Note that the scales resolution must be to 100ths of a gram (0.00) or better. Alternatively find out the pellet weight from the supplier or manufacturer.
- To use the formula below the weight must be in grains. To change from grams to grains multiply by 15.432. i.e. 0.69 grams x 15.432 = 10.65 grains.
- Use the formula $(FPS \times FPS \times Weight) / 450240 = \text{Muzzle Energy}$. i.e. $(700 \times 700 \times 10.65) = 5218500$ divide by 450240 = 11.59ft/lbs.

The current legal limit is 12ft/lbs.

If the rifle is not performing as it should, get advise from the supplying dealer or AIR ARMS.

FILLING INSTRUCTIONS

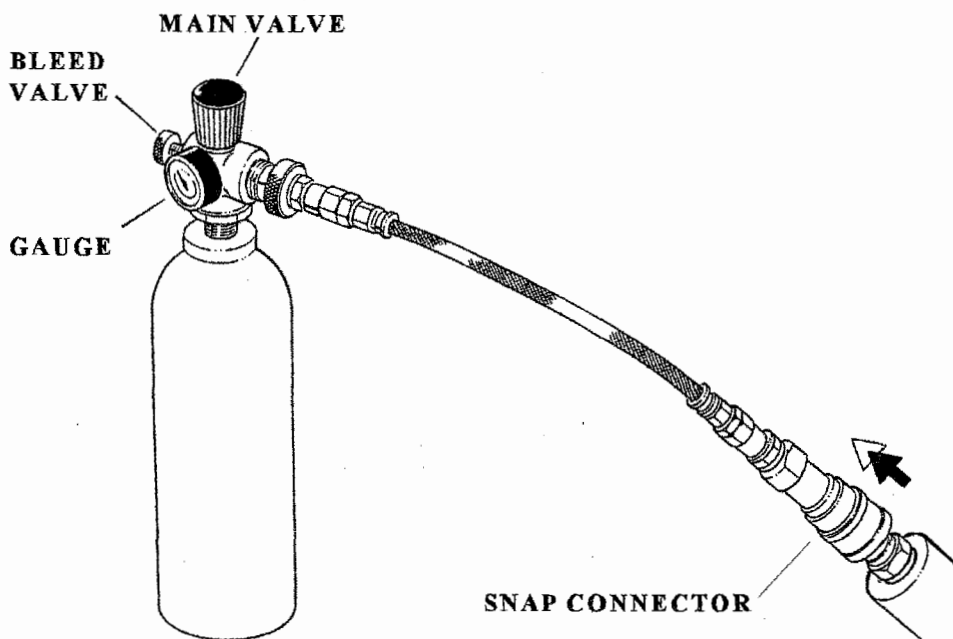

NOTE! - If the rifle is empty of air it must be cocked prior to filling. Air will exhaust from the barrel if this is not done.

- Remove the end cap from the front of the rifle. The cap is removed by pulling in line with barrel.
- Pull the operation ring back on the snap connector fitted to the end of the hose and push onto the male connector on the rifle.
- Check that the bleed valve on the filling cylinder is closed (turn clockwise to close).
- Slowly open main valve (anti-clockwise) and observe gauge. When gauge indicates 200 bar, close main valve. (**NOTE!** At least 80 bar pressure is required inside the cylinder before the filling valve will seal. (Air may be heard to escape from the barrel until this pressure is reached). The rifle can be filled to lower pressures but the number of shots obtained will be less than normal. Minimum working pressure is 110 bar.
- Open bleed valve (anti-clockwise) to release air in filling hose.
- Release snap connector by pulling operating ring backwards and disengaging.
- Replace end cap.

NOTE!

If the rifle is continually fired when the pressure in the cylinder is below refill pressure, all remaining air will eventually exhaust through the barrel spontaneously. This is not harmful to the rifle but can cause surprise to the shooter or bystanders. In this case the rifle must be cocked before re-filling.

OPERATING INSTRUCTIONS

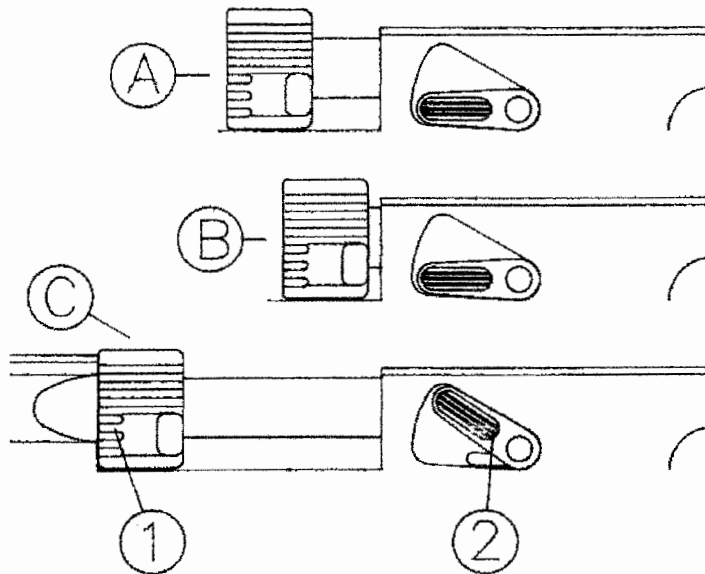

COCKING

- (1) Breech Block
- (2) Release Lever

- (A) Breech Block in spring-back position
- (B) Breech Block in cocked position
- (C) Breech Block in ready to fire position

The Pro-Target should always be stored and/or transported with the Breech Block in the spring back position.

LOADING

- With the Breech Block in position (A), pull Block back until in position (B).
- Insert pellet.
- Push Block forward until Release Lever clicks into the fully up position.
- The rifle is now ready to fire.
- Immediately after firing push release lever down until the Breech Block springs back to position (A).

It is quite safe to test fire this rifle without loading a pellet. However **never** cock and fire with an empty or removed cylinder.

TRIGGER ADJUSTMENT

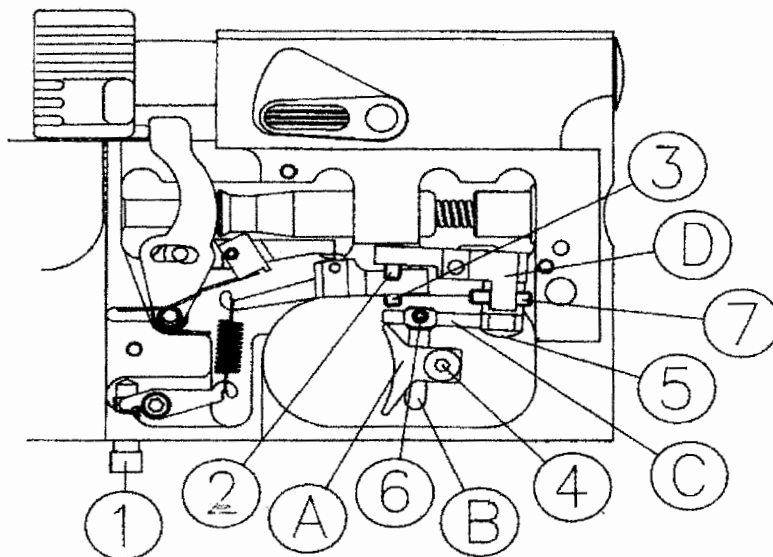

TRIGGER ADJUSTMENT

- | | |
|---|-------------------------|
| (1) Trigger weight of pull adjuster screw | (A) Trigger Shoe |
| (2) 1 st Stage length of travel adjuster screw | (B) Trigger Pillar |
| (3) 2 nd Stage adjuster screw | (C) Trigger Bar |
| (4) Trigger Shoe locking screw | (D) Trigger Pivot Block |
| (5) Trigger Bar locking screw | |
| (6) Trigger Pillar locking screw | |
| (7) Follow-through travel adjuster screw | |

The position of the trigger shoe can be adjusted in three planes as below:

- Vertically - Loosen screw (4) and slide Shoe up/down on Trigger Pillar.
- Longitudinally - Loosen screw (6) and slide Trigger Pillar along Trigger Bar.
- Radially - Loosen screw (5) and turn Trigger Bar on Pivot Block.

TRIGGER WEIGHT OF PULL ADJUSTMENT

The weight of pull is adjusted by turning screw (1) clockwise to increase and anticlockwise to decrease the weight of pull. Access to screw (1) is from underneath the stock, adjacent to the rear stock fixing screw.

1st STAGE LENGTH OF TRAVEL ADJUSTMENT

1st Stage travel adjustment is by screw (2). Turn the screw clockwise to decrease and anticlockwise to increase travel.

2nd STAGE ADJUSTMENT

2nd stage adjustment is by screw (3). Turn the screw anticlockwise to increase and clockwise to decrease the travel between the end of the 1st stage travel and beginning of 2nd stage. If the screw is turned too far clockwise the rifle will fire before the end of the 1st stage travel is reached.

FOLLOW-THROUGH TRAVEL ADJUSTMENT

Follow-through adjustment is by screw (7). Turn the screw clockwise to decrease and anticlockwise to increase the amount of trigger travel after the let-off point.

STOCK ADJUSTMENT

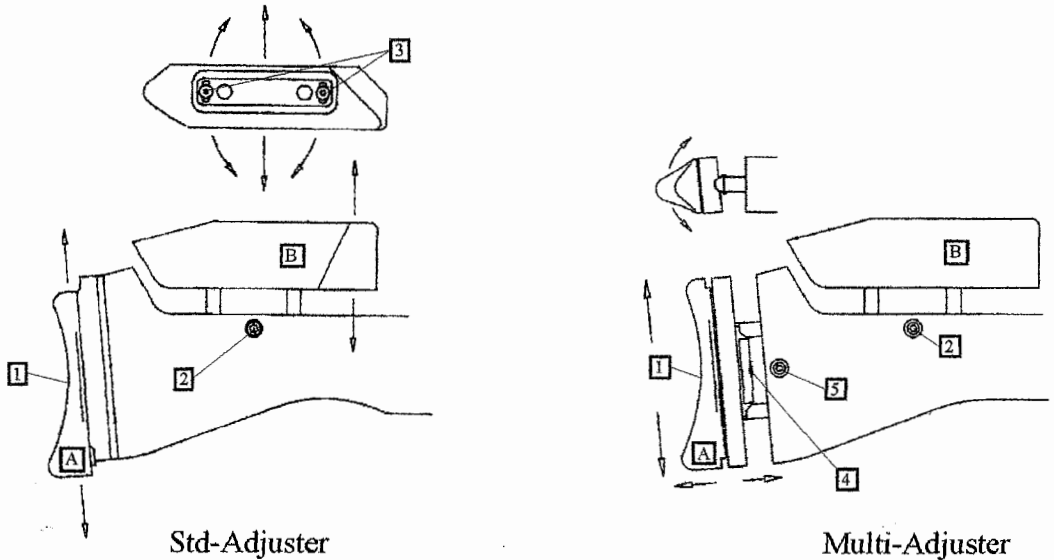

SHOULDER PAD ADJUSTMENT - STD ADJUSTER

- (1) Shoulder Pad locking screw
- (2) Cheekpiece vertical locking screw
- (3) Cheekpiece lateral and radial locking screw
- (A) Shoulder Pad
- (B) Cheekpiece

The position of the Shoulder Pad can be moved in one plane as follows:

- Vertically - Loosen screw (1), adjust height, re-tighten screw (1).

SHOULDER PAD ADJUSTMENT - WITH OPTIONAL MULTI-ADJUSTER

- (1) Shoulder Pad fixing screw
- (2) Cheekpiece vertical locking screw
- (3) Cheekpiece lateral locking screw
- (4) Shoulder Pad locking screw
- (5) Shoulder Pad longitudinal locking screw
- (A) Shoulder Pad
- (B) Cheekpiece

The position of the Shoulder Pad can be moved in three planes as follows:

- Vertically - Loosen screw (4), adjust height, re-tighten screw (4).
- Longitudinally - Loosen screw (5), adjust length, re-tighten screw (5).
- Radially - Loosen screw (4), adjust position, re-tighten screw (4).

CHEEKPIECE ADJUSTMENT - BOTH TYPES

The position of the Cheekpiece can be moved in two planes as follows:

- Vertically - Loosen screw (2), adjust height, re-tighten screw (2).
- Radially - Loosen screw (3), adjust position, re-tighten screw (3).
- Laterally - Loosen screw (3), adjust position, re-tighten screw (3).

GENERAL MAINTENANCE

Regularly check the tightness of all fixings. Do not over-tighten, many parts are made from aluminium, stripped threads will result from over-tightening.

Regularly clean the barrel with a good quality cleaner and pull through. For optimum accuracy clean the barrel after 100 shots.

To minimise potential damage to the barrel, it is advised not to use metal cleaning rods and cleaning brushes unless absolutely necessary. If metal cleaning equipment is used be very cautious.

NOTES

GENERAL LUBRICATION

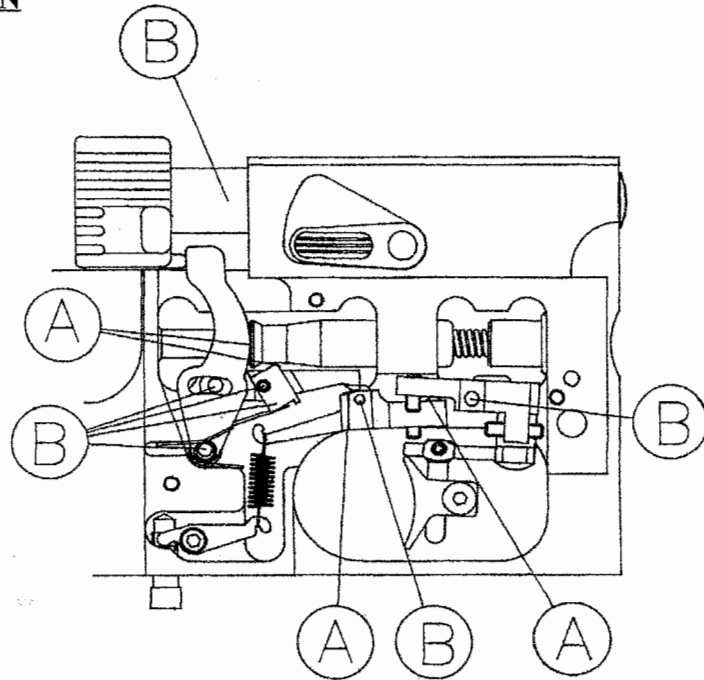

The wear parts of the Pro-Target have been designed to require minimal lubrication during normal use. The lubrication applied to the internal parts during assembly at the factory is normally sufficient for 10000 shots, any roughness of operation may indicate that lubrication is necessary before this number.

If you have limited knowledge of the workings of a precision mechanism, maintenance and lubrication is best left to an experienced gunsmith or preferably the factory.

It is essential to wipe over the external surfaces of the rifle with a soft oily rag to maintain the high surface finish. Failure to do this will result in surface corrosion.

Regular internal lubrication is unnecessary. If the operation of the rifle becomes rough, stiff or noisy, this may indicate that lubrication is required and should be investigated.

Do **not** allow any lubrication to contact the striker or striker bearings, parts RN200FT and RN103.

It is strongly advised that this rifle is serviced by Air Arms or a competent gunsmith. The frequency of services are determined by the amount of use, but in any case should be at least once a year.

Under and/or over lubrication will effect the operating consistency of this rifle.

Points (A), lubricate with Moly Grease

Points (B), lubricate with a low viscosity mineral oil

POINTS A

- (a) Cocking Arm/Striker contact point
- (b) Top Sear/Middle Sear contact point
- (c) Trigger cam point
- (d) Striker/Catch Plate contact point

POINTS B

- (e) Breech Shaft
- (f) Top Sear pivot pin
- (g) Cocking Arm pivot pin
- (h) Striker Catch Plate pivot pin
- (i) Pivot Block pivot pin

SILICONE OR SYNTHETIC BASED OILS OR GREASES SHOULD NEVER BE USED ON MOVING PARTS.

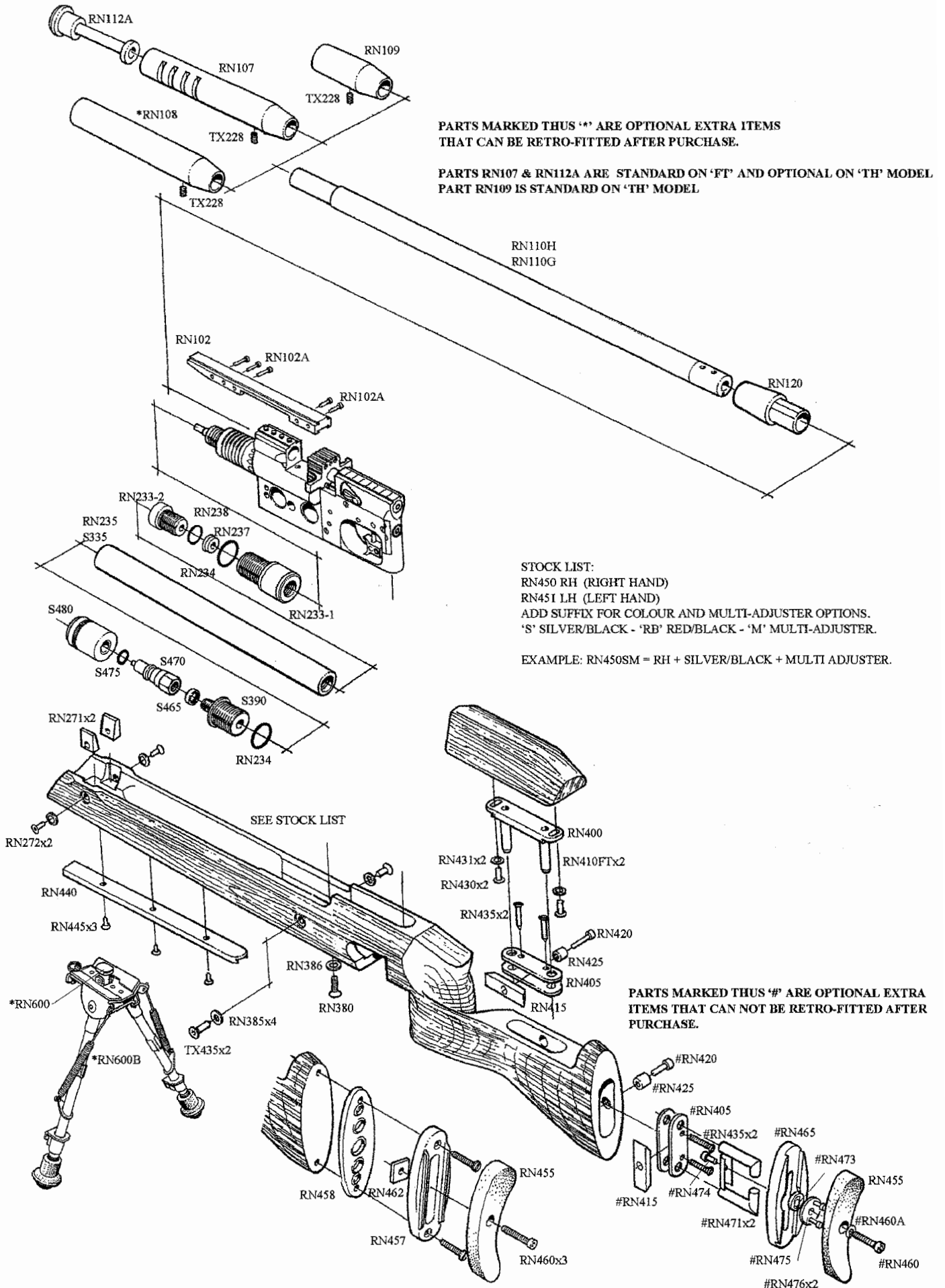

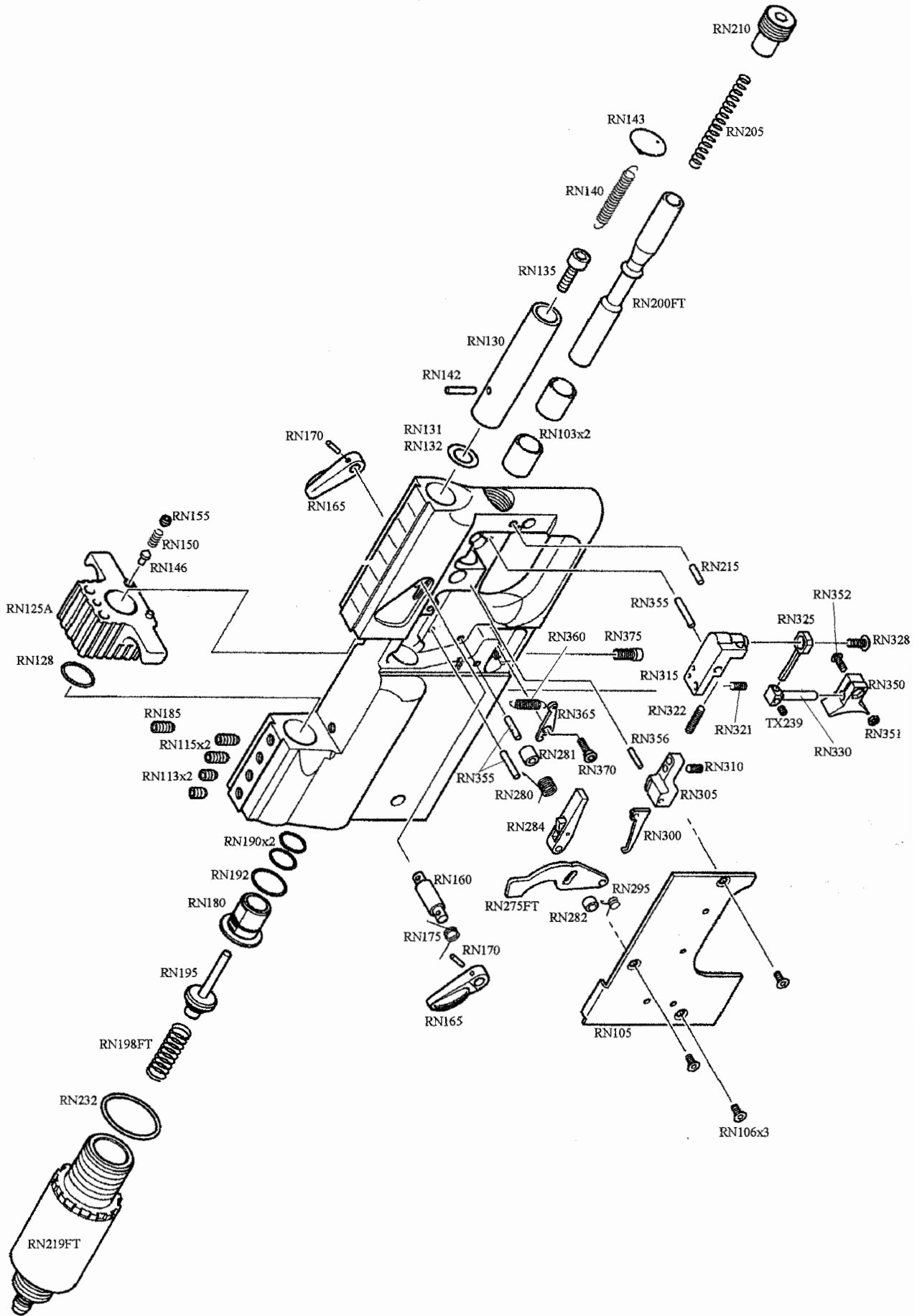

PARTS LIST - PRO-TARGET FT & TH MODELS

RN102	SCOPE MOUNT	RN305	MIDDLE SEAR BLOCK
RN102A	SCOPE MOUNT SCREW	RN310	ADJUSTER SCREW
RN103	STRIKER BUSH	RN315	TRIGGER PIVOT BLOCK
RN105	COVER PLATE	RN321	ADJUSTER SCREW
RN106	COVER PLATE SCREW	RN322	ADJUSTER SCREW
RN107	MUZZLE END (FT)	RN325	TRIGGER BAR
RN108	SOUND MODERATOR	RN328	FIXING SCREW
RN109	MUZZLE END (TH)	RN330	TRIGGER PILLAR
RN110G	BARREL (TH .22 cal)	RN350	TRIGGER SHOE
RN110H	BARREL (FT & TH .177 cal)	RN351	NUT (M3)
RN112A	BARREL TUBE INSERT	RN352	FIXING SCREW
RN113	SCREW	RN355	CHASSIS PIN
RN115	SCREW	RN356	CHASSIS PIN
RN120	BARREL SUPPORT	RN360	TRIGGER SPRING
RN125A	BREECH BLOCK	RN365	SPRING PLATE
RN128	BREECH BLOCK 'O' RING	RN370	FIXING SCREW
RN130	BREECH SHAFT	RN375	ADJUSTER SCREW
RN131	BREECH SHAFT SHIM (0.10mm)	RN380	STOCK SCREW (LOWER)
RN132	BREECH SHAFT SHIM (0.15mm)	RN385	STOCK WASHER (SIDE)
RN135	BREECH SHAFT SCREW	RN386	STOCK WASHER (LOWER)
RN140	BREECH RETURN SPRING	RN400	ADJUSTER TOP PLATE
RN142	RETURN SPRING PIN	RN405	ADJUSTER BOTTOM PLATE
RN143	RETURN SPRING RETAINER	RN410FT	ADJUSTER PILLAR
RN146	BREECH BLOCK PLUNGER	RN415	ADJUSTER LOCKING PLATE
RN150	PLUNGER SPRING	RN420	LOCKING SCREW
RN155	PLUNGER SPRING	RN425	LOCKING BUSH
RN160	BREECH RELEASE SHAFT	RN430	TOP PLATE SCREW
RN165	BREECH RELEASE LEVER	RN431	TOP PLATE WASHER
RN170	RELEASE LEVER PIN	RN435	ADJUSTER BOTTOM PLATE SCREW
RN175	RELEASE LEVER SPRING	RN440	STOCK RAIL
RN180	FIRING VALVE SEAT	RN445	RAIL SCREW
RN185	SCREW	RN450	STOCK (RIGHT HAND)
RN190	VALVE SEAT 'O' RING	RN451	STOCK (LEFT HAND)
RN192	VALVE SEAT 'O' RING	RN455	BUTT PAD
RN195	FIRING VALVE	RN457	BUTT PAD BASE
RN198FT	FIRING VALVE SPRING	RN458	BUTT PAD SPACER
RN200FT	STRIKER	RN460	SCREW
RN205	MAIN SPRING	RN460A	SPRING WASHER
RN210	MAIN SPRING ADJUSTER	RN462	LOCKING PLATE
RN215	ADJUSTER LOCKING PAD	RN465	BUTT PAD BASE
RN219FT	REGULATOR ASSEMBLY	RN471	HINGE PIN
RN232	REGULATOR 'O' RING	RN473	SLIDING NUT
RN233-1	CYLINDER END PLUG OUTER	RN474	LOCKING SCREW
RN233-2	CYLINDER END PLUG INNER	RN475	FIXING PLATE
RN234	CYLINDER 'O' RING	RN476	FIXING PLATE SCREW
RN235	CYLINDER TUBE (TH)	RN600	BI-POD FIXING LUG
RN237	LIP SEAL	RN600B	BI-POD
RN238	END PLUG 'O' RING	S335	CYLINDER TUBE (TH)
RN271	STOCK INFILL	S390	CYLINDER END PLUG (FILLING)
RN272	STOCK SCREW (FRONT)	S465	BONDED SEAL

PARTS LIST - CONTINUED

RN275FT	COCKING ARM	S470	SNAP CONNECTOR
RN280	TOP SEAR SPRING	S475	END CAP 'O' RING
RN281	COCKING ARM SPACER (INNER)	S480	END CAP
RN282	COCKING ARM SPACER (OUTER)	TX228	SCREW
RN284	TOP SEAR ASSEMBLY	TX239	PILLAR SCREW
RN295	RETURN SPRING	TX435	STOCK SCREW (REAR)
RN300	MIDDLE SEAR		

IT IS HIGHLY RECOMMENDED THAT ONLY GENUINE AIR ARMS PARTS ARE USED IN THIS RIFLE.

THE USE OF NON-GENUINE PARTS WILL INVALIDATE YOUR WARRANTY.

PLEASE QUOTE THE RIFLE NUMBER AND PART NUMBERS IN ANY CORRESPONDENCE.

THIS RIFLE WAS SET-UP AND TESTED USING AIR ARMS PELLETS AS INDICATED BELOW.

AIR ARMS HUNTER .22	16.4 grains	
AIR ARMS FIELD .22	16.4 grains	
AIR ARMS FIELD .177	8.4 grains	

USING THE CORRECT PELLET IS VERY IMPORTANT FOR ACCURACY AND PERFORMANCE OF YOUR RIFLE. AIR ARMS PELLETS ARE HIGH QUALITY PRECISION PRODUCTS AND WILL GIVE EXCELLENT RESULTS THAT WILL BE EQUAL TO OR BETTER THAN ANY OTHER PELLET CURRENTLY AVAILABLE.

IF YOU CHOOSE NOT TO USE AIR ARMS PELLETS IT IS MOST IMPORTANT THAT YOU READ PAGE 2 OF THIS HANDBOOK IN RESPECT OF CHECKING VELOCITY AND CALCULATING MUZZLE ENERGY.